

Cable Television: The Industry Today and Its Outlook for the Future

Summary

The cable television industry is facing enormous changes in the telecommunications and broadcasting markets and in the technological landscape as well. Multichannel broadcasters are experiencing sluggish growth, and even internet operators, which had proved strong until now, are being forced by fierce competition into exploring new business strategies. Struggling to cope with the advent of broadband, smart television, and other new services, growing numbers of cable television firms are turning to alliances to boost their competitiveness. How these strategic alliances will be implemented, both by firms and communities, is a matter of keen interest throughout the industry.

This paper is a summary of the report *Present State of the Cable Television Industry, FY 2012 Edition* (“the FY 2012 Report”).

1. Markets for streaming content and triple play service

An important feature of today’s cable television industry is the rapid advancement of broadcasting services using communications technology. Smart televisions combining video and internet services and linking television and mobile terminals are growing increasingly popular in areas where mobile broadband and mobile terminals are in wide use. Firms are competing to provide the most user-friendly experience in terms of the freedom to choose viewing time, place, and package, in addition to the upper-layer content which has long been a major part of cable television’s appeal (Figure 1).

Figure 1 Diversification of Content Audience

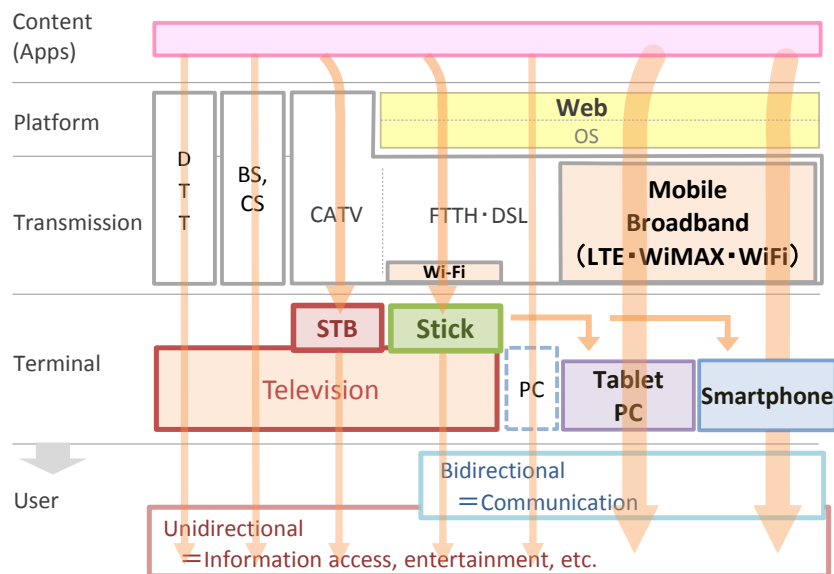

Source: Development Bank of Japan Inc.

① **The multichannel market**

IP multicast broadcasting has driven growth in the multichannel market for the past several years. If IP multicast were omitted, FY 2012 results would be level with those of the previous year (Figure 2). The number of cable subscribers showed a decline of 0.1% year-on-year, greatly reducing its contribution to the growth of the multichannel market. The precipitous fall in cable subscriptions is a trend that bears watching.

Figure 2 Changes in the Multichannel Market (Subscriber Households)

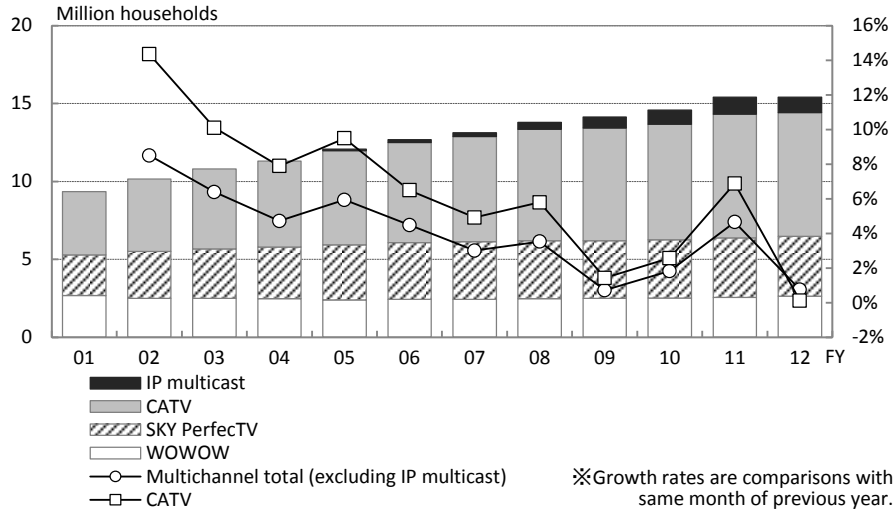

Source: Ministry of Internal Affairs and Communications; Hoso Journal - sha Inc.; Corporate investor relations materials

② **The broadband market**

Fiber-to-the-home (FTTH) drove growth in the broadband market until about 2010. Since 2011, however, a huge increase in subscriptions to 3.9 generation mobile telephone terminal packets (long-term evolution, or LTE) has brought new growth to the broadband market (Figure 3). Mobile broadband (such as WiMAX), including broadband wireless access (BWA), is rapidly becoming the chief driver of growth in this market.

Figure 3 Changes in the Broadband Market (Subscriber Households)

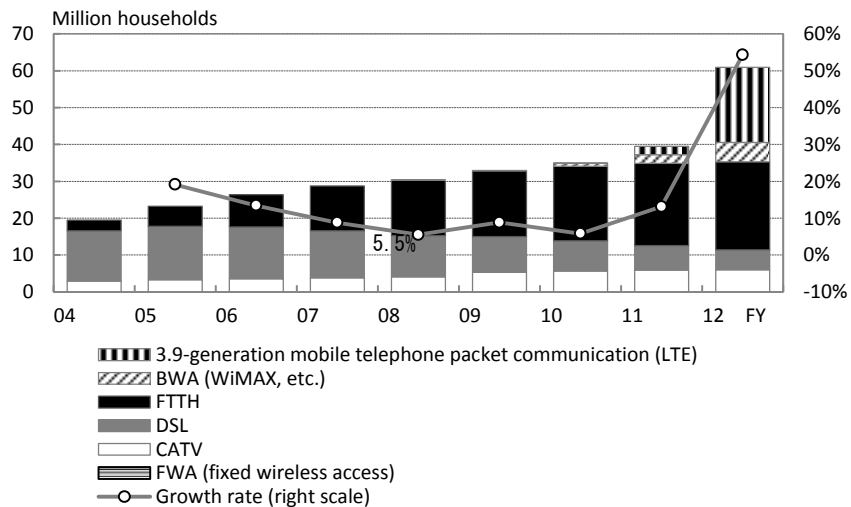

Source: Ministry of Internal Affairs and Communications

③ The telephone market

The number of landline subscriptions peaked in 1998 and has since been on a gradual decline (Figure 4). While OABJ-IP subscriptions have increased, the falling number of NTT subscriptions has kept the number of landline subscribers as a whole on the decline. Mobile telephone subscriptions, on the other hand, are showing strong and steady growth, the number reaching 131 million as of the end of fiscal year 2012. Growing numbers of users are replacing their landlines with mobiles, and signs point to a greater presence for LTE as a mobile broadband circuit. The spread of smartphones in the past few years has brought a proliferation of free applications; it will be interesting to see what kind of impact these will have on the telephone industry.

Figure 4 Changes in Numbers of Landline Subscribers

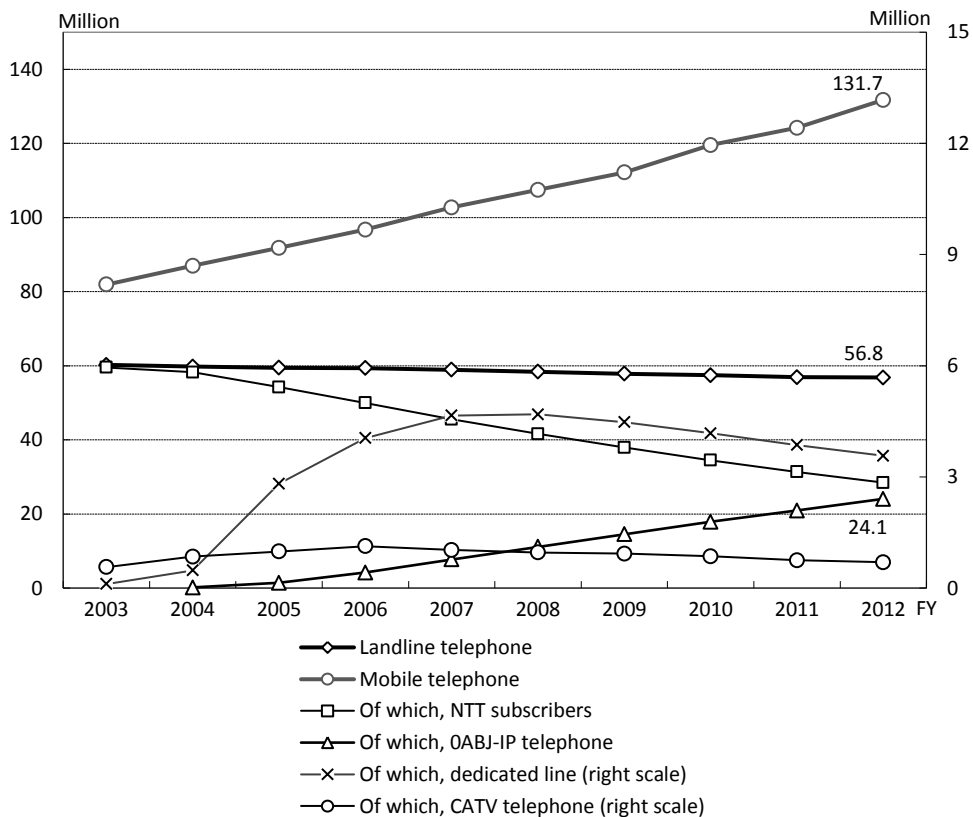

Notes

1. Source: Ministry of Internal Affairs and Communications

2. IP telephone services provided by CATV operators are counted under IP telephones.

2. Trends in cable television businesses

① Broadcasting

The FY 2012 Report is based on responses from some 150 cable television operators across Japan. In FY 2012, the multichannel subscription rate was 20.4% per company, continuing a year-on-year decline in the number of subscribing households (Figure 5).

The number of households acquiring or cancelling multichannel subscriptions maintained sluggish growth (for MSOs¹) or went into a slight decline (for non-MSOs) (Figure 6).

¹ Multiple system operator: A company owning multiple cable systems.

Figure 5 Changes in Numbers of Multichannel Subscriber Households and Subscription Rates, Per Firm (n = 96)

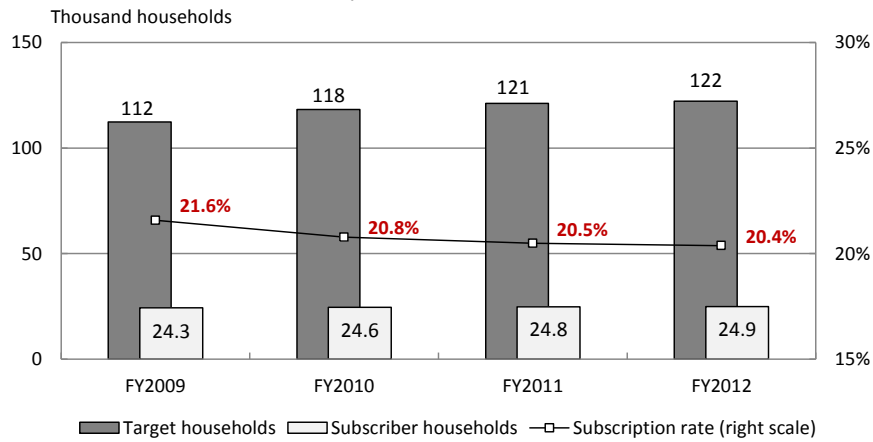

Source: Development Bank of Japan Inc.

Figure 6 Changes in Multichannel Acquisitions/Cancellations, Per Firm

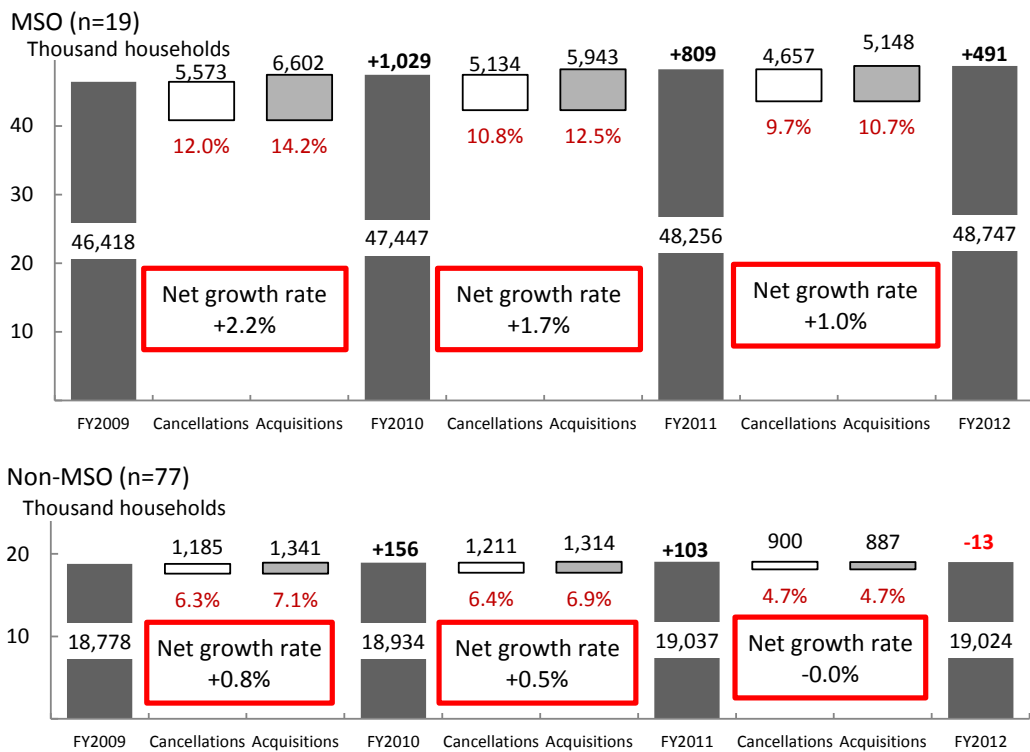

Source: Development Bank of Japan Inc.

When questioned as to the reasons for the cancellation of services, the greatest number of respondents replied that it was due to the subscribers' "moving house." The percentage of respondents giving this answer was particularly high among MSOs, which operate primarily in urban areas (Figure 7). The reason "Don't use these services" showed sharp growth in the current fiscal year, probably due at least in part to the diversification of tastes that has come with the spread of smartphones and similar devices.

Figure 7 Changes in Reasons for Cancellation Over Time

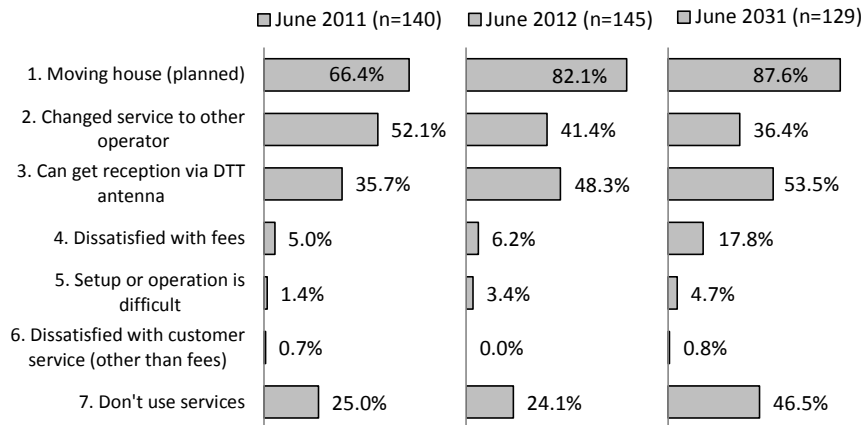

Source: Development Bank of Japan Inc.

The change of multichannel subscriptions to digital had kept ARPU² rising through FY 2012, but it has been falling off since then (Figure 8). This is probably the result of factors such as the completion of terrestrial digitalization and discounts designed to promote subscriptions. Comparing trends for MSOs and non-MSOs in FY 2012, we see that figures for non-MSOs remained generally level while those for MSOs continued on a downward trend. MSOs' sales promotions for low-end plans are believed to have contributed to this trend.

² Average revenue per user: Monthly revenue sales per subscriber.

Figure 8 Changes in Multichannel ARPU (Average for All Firms in FY 2009 = 100)

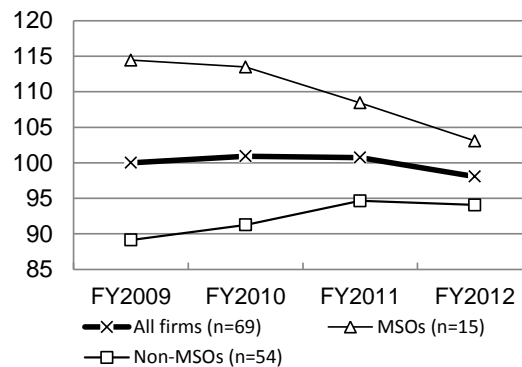

Source: Development Bank of Japan Inc.

② Communications

The number of households subscribing to cable internet rose by 13.2% in FY 2012 (Figure 9). This increase in the subscription rate was partly due to an increase in the number of target households that came after a quarter of all operators expanded their service areas. New subscribers were also attracted by the introduction of diversified menus and high-speed plans.

In general, both subscriptions and cancellations are moving slowly upward, although at a declining pace. Cancellations rates for non-MSOs are on the increase, however, while the acquisition rate for FY 2012 declined (Figure 10).

Figure 9 Changes in Numbers of Cable Internet Subscriber Households and Subscription Rates, Per Firm (n = 102)

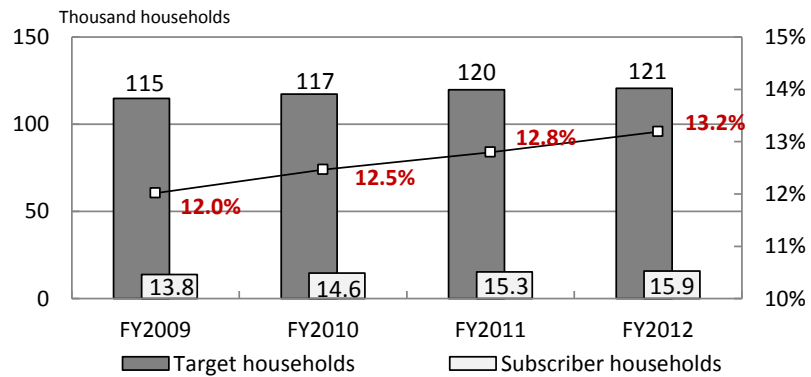

Source: Development Bank of Japan Inc.

Figure 10 Changes in Cable Internet Acquisitions/Cancellations, Per Firm

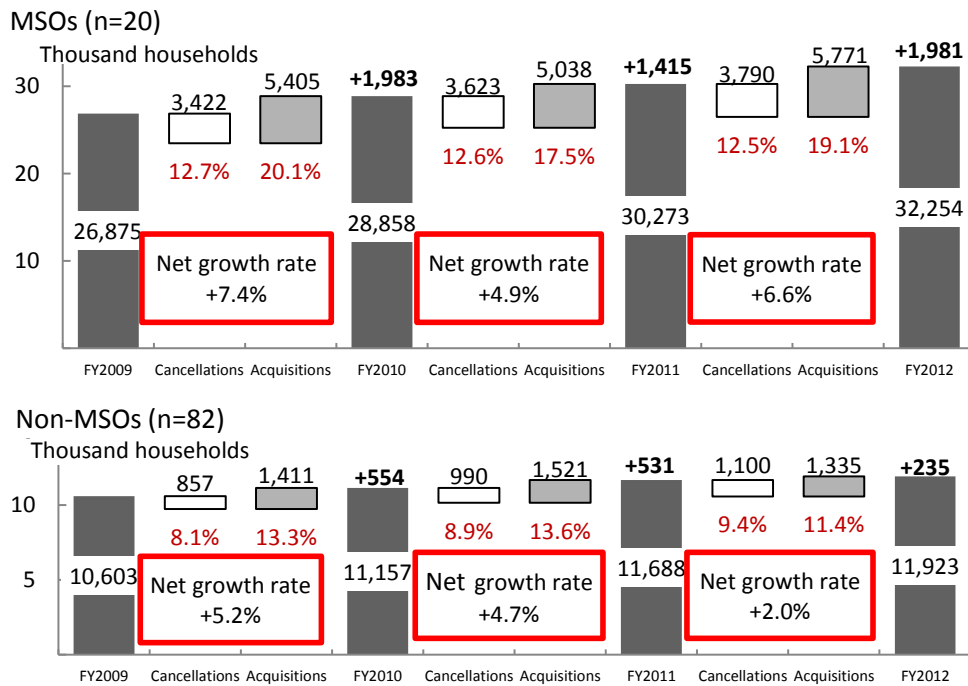

Source: Development Bank of Japan Inc.

From FY 2009 through FY 2012, the average ARPU for all firms displayed a downward trend. The decline was especially large in FY 2012 (Figure 11). Notably, MSO operators saw their year-on-year ARPU drop steeply that year. The reason is thought to be sales strategies stressing customer retention, along with intense competition from telecom operators.

Looking at plans with the greatest number of subscribers over the last five years, we see a drop in the percentage of operators offering 2Mbps, the slowest speed, combined with a sustained rise in the percentage of those offering 20Mbps, the fastest speed – both signs of a general transition from slow- to high-speed plans (Figure 12).

Figure 11 Changes in Cable Internet ARPU

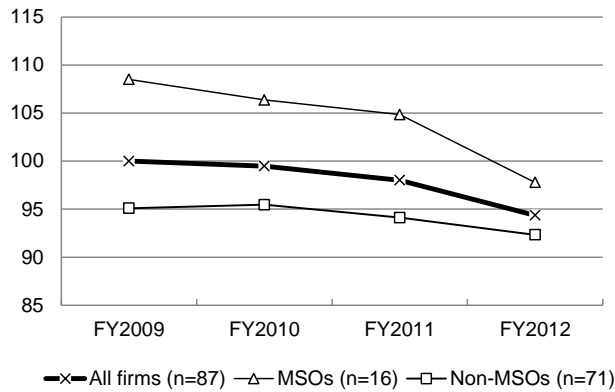

Source: Development Bank of Japan Inc.

Figure 12 Speed of Most Popular Service of Subscribers with Each Operator

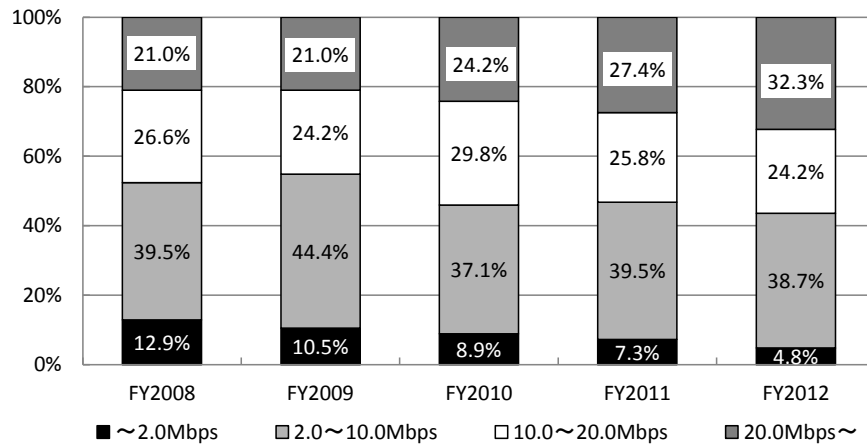

Source: Development Bank of Japan Inc.

③ Landline services

As landline services have been launched relatively recently, there are many operators with much room for growth. Subscriber households and subscription rates are increasing steadily (Figure 13).

Figure 13 Changes in Numbers of Landline Subscriber Households and Subscription Rates, Per Firm (n = 42)

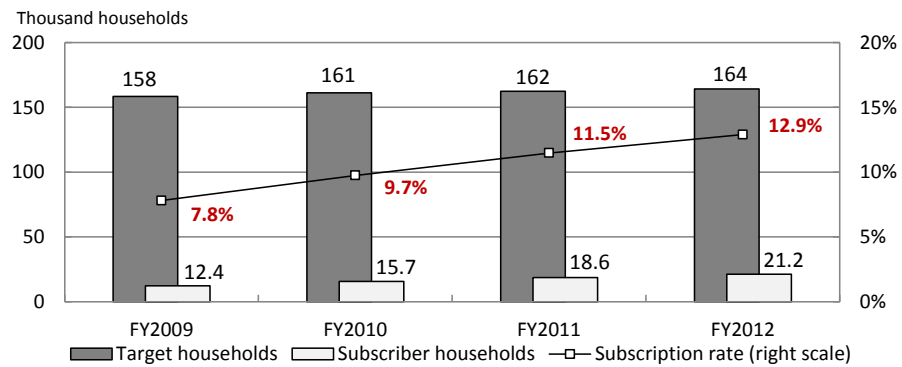

Source: Development Bank of Japan Inc.

With MSOs giving precedence to landline services, as of FY 2008 a substantial gap existed between the ratios of MSOs and non-MSOs. Over the last five years, however, even non-MSOs have been introducing landline services at a growing rate; over 60% now handle landline.

Among non-MSOs, subscription rates for landline services are lower than those for multichannel services. Therefore, non-MSOs hope to sustain their growth trend by expanding sales to existing subscribers. MSOs cannot expect much more than sluggish growth in this category, as their subscription rates for landline services already approach those for multichannel (Figure 14).

Figure 14 Changes in Landline Acquisitions/Cancellations, Per Firm

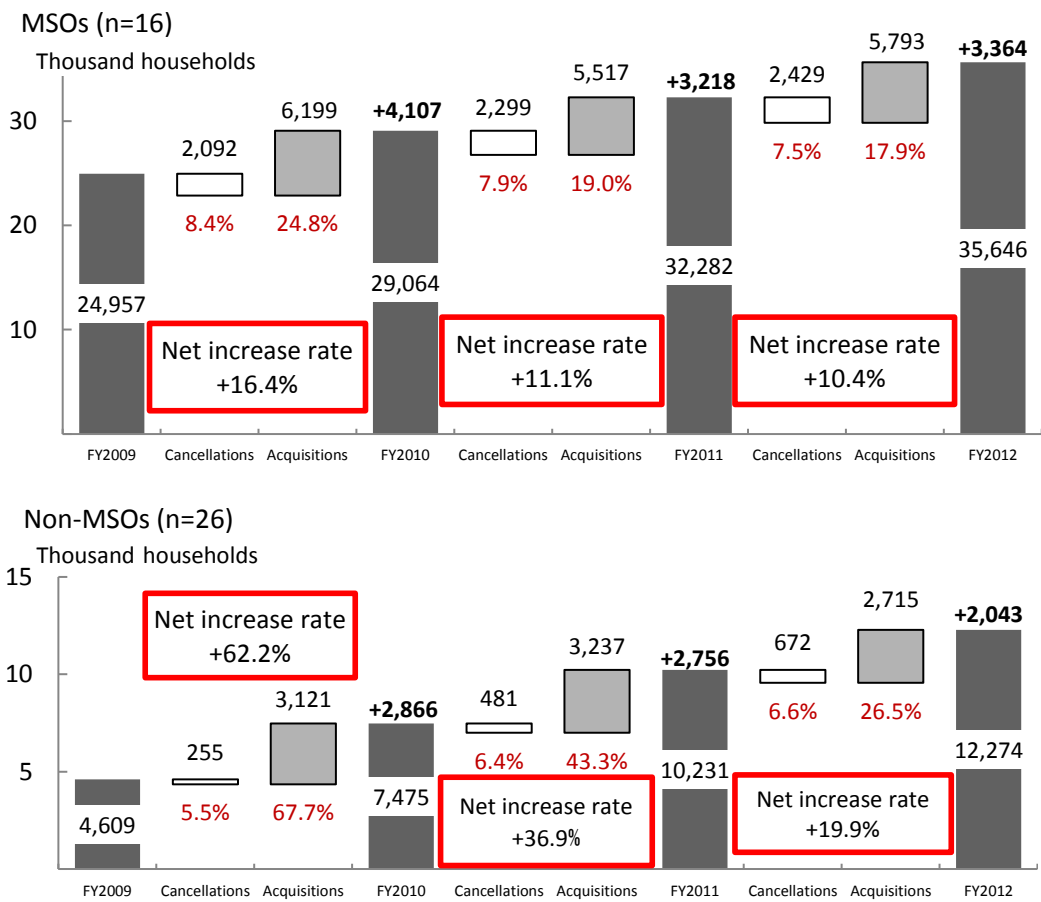

Source: Development Bank of Japan Inc.

3. Business conditions

According to the FY 2012 Report, revenue earned by cable television firms in FY 2012 failed to grow from the previous year's level. The sluggishness of the year-on-year growth rate was conspicuous.

An analysis of business earnings shows little change: revenue from broadcasting and other businesses was essentially flat, even while that from communications business was on the rise (Figure 15).

Figure 15 Changes in Earnings for Each Type of Business (Average for DBJ Clients)

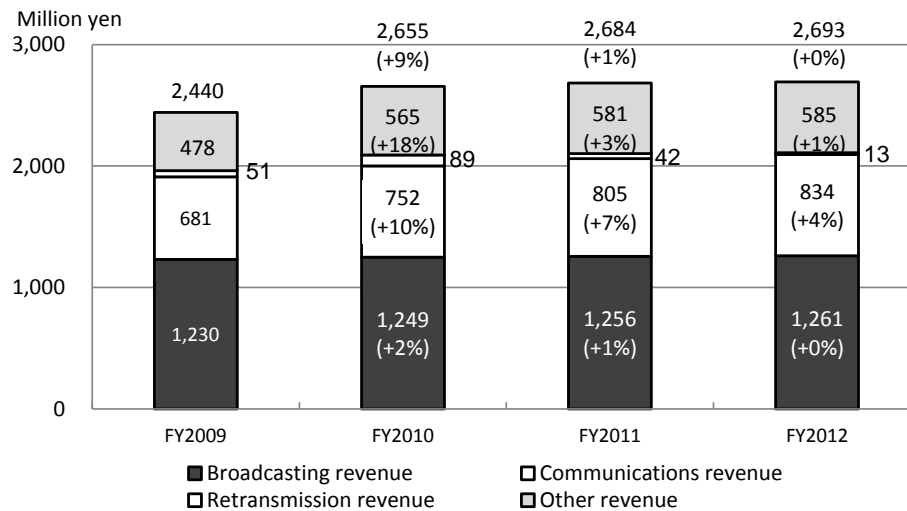

Source: Development Bank of Japan Inc.

The average of total assets for all companies showed a contracting tendency, with a progressive shrinking of interest-bearing debt over three fiscal years (Figure 16). With sustained current-term surpluses producing accumulated income, net assets took up a growing proportion on the creditor side (right-hand side of the figure).

Figure 16 Average Operator's Balance Sheet

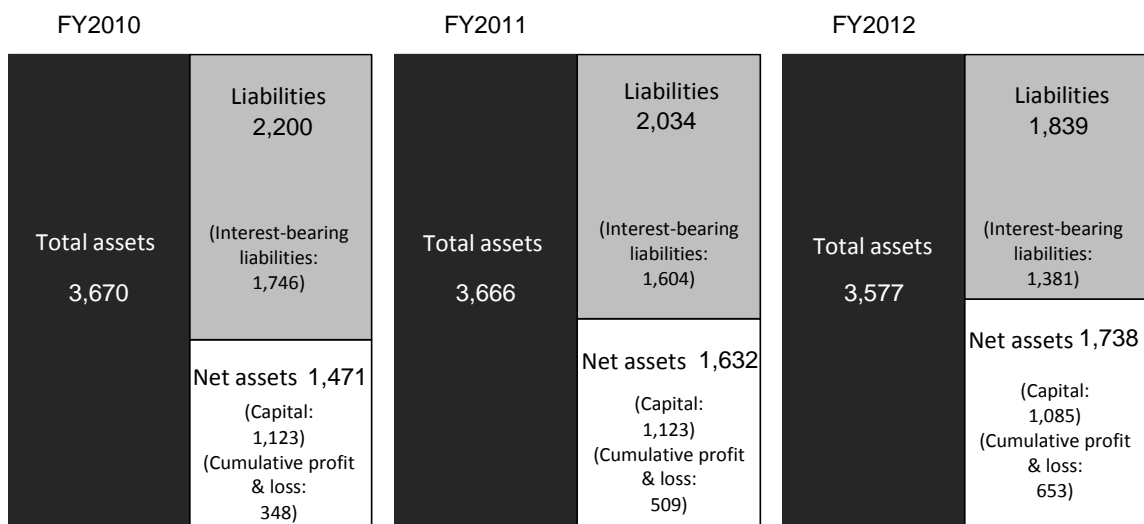

Source: Development Bank of Japan Inc.

4. Recent activity in communications and broadcasting

① Development of smart televisions by carriers

As smart television enters the realm of commercial viability within the cable television industry, mobile communications carriers have simultaneously rolled out smart television services using their own stick terminals. The aim is to expand to home televisions content that communications carriers have gathered and constructed for smartphones.

② Moves toward platform development

With the industry facing difficult circumstances both outside and within, some firms are moving to establish a “cable platform” aimed at improving the competitiveness of the industry as a whole. An exploratory committee within the Japan Cable and Telecommunications Association has focused on developing regional potential. At the Ministry of Internal Affairs and Communications (MIC), the Study Group for Acceleration of Broadcasting Services has formed a Cable Platform Working Group to look at ways of creating a proprietary platform for the cable television industry. In a report issued in May 2013, the MIC set down five capabilities required of such a platform (Figure 17).

Figure 17 Five Functions Required of a Platform, According to MIC

①	IP video transmission capabilities
②	Platform for alliances among existing ID operators
③	Monitoring platform
④	AJC-CMS capabilities
⑤	Customer management system (SMS) platform capabilities

Source: Ministry of Internal Affairs and Communications

Operators have also been moving ahead with a number of initiatives.

Japan Digital Serve Corporation (JDS), for example, is building a platform involving a tie-up with IP-based video on demand provided by Jupiter Telecommunications Co., Ltd. (J:COM).

In another new development, J.COTT Inc., a collaboration among several independent cable operators, is working with firms including Actvila Corporation to create a platform that would enable firms throughout Japan to provide VOD and other services.

5. Moves to advance alliances

① The situation in the United States

Like their counterparts in Japan, local independent operators in the U.S. face stiff competition from rivals in the communications sector. Their difficulties are compounded by listless regional economies, competition from satellite broadcasters, and repercussions of government policy. Some independent firms are fighting back by forming alliances among themselves.

The National Cable Television Cooperative (NCTC) is a partnership of independent operators. In addition to making joint purchases and handling rights, the NCTC recently launched the TV Everywhere platform aimed at small and medium-sized firms. The American Cable Association (ATA) handles office work relating to retransmission legislation while coordinating with the FCC. The two organizations cooperate in providing support to independent operators (Figure 18).

Figure 18 The Alliance Situation in the United States

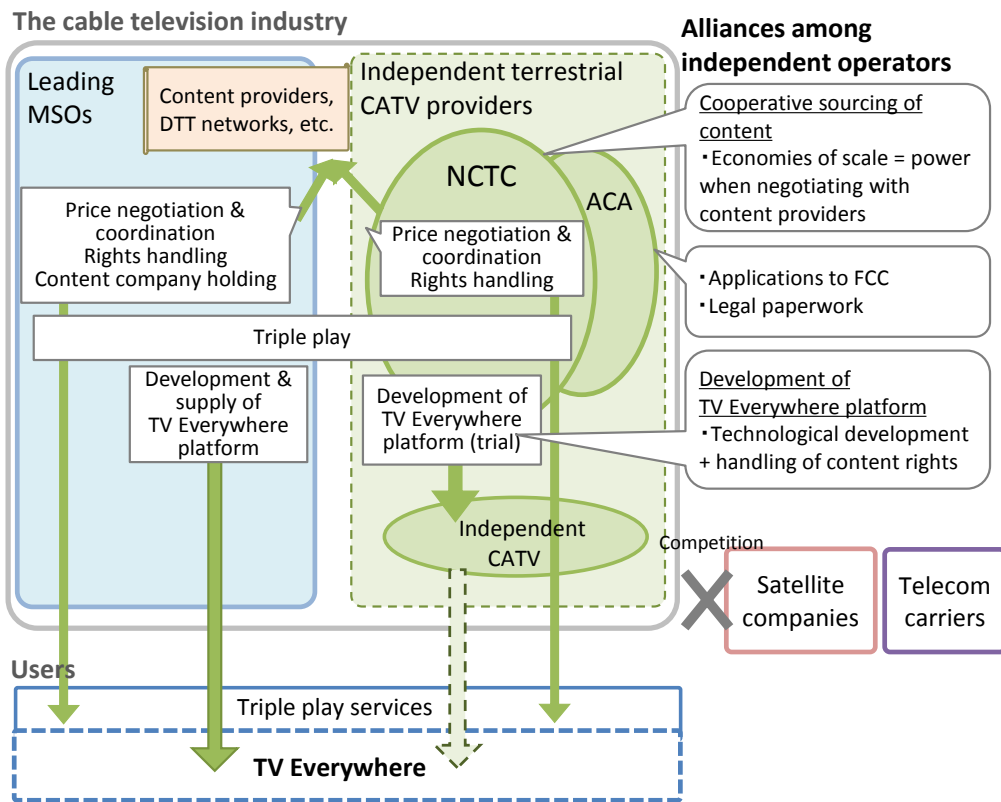

Source: Development Bank of Japan Inc.

A number of consulting services have sprung up to assist independent operators in introducing Internet Protocol television (IPTV) and over-the-top content (OTT) services by handling the rights to technology and programs (Figure 19).

The U.S. Midwest is home to the Mid-American Cable Show, an annual gathering of independent operators from across the region. In 2013 the show was held from September 4-6 in Springfield, Missouri. Sessions included presentations by the NCTC and TV Everywhere, an alliance of independent operators, during which they described their activities and outlined technological road maps (Figure 20). At the exhibition booths visitors could watch local high school teams compete in football and basketball games in broadcasts presented on tablets and other devices, showcasing independent operators at their best (Figure 21).

Individual firms are paying attention to the tie-up trend. Responding to our questionnaire, one local independent operator said that since TV Everywhere was likely to extend into outlying regions, independents should facilitate its spread through alliances with ① MSOs and ② cooperatives of small to medium-sized operators such as the NCTC. Some firms said they were seeking to expand their business through alliances with nearby power companies. Some, however, were concerned that tie-ups could cost independents their individuality, at least to some extent.

Figure 19 OTT/IPTV Services for Regional Telephone Companies and CATV Operators
(Photo is of Skitter TV)



Source: Skitter, Inc.

Figure 20



Source: Development Bank of Japan Inc.

Figure 21



Source: Development Bank of Japan Inc.

② Japanese views on alliances

In a climate of intensifying competition and constant technological innovation, momentum appears to be growing for alliances within the cable television industry. For the FY 2012 Report, we asked Japanese cable operators about their intentions in regard to alliances. More than 80% of the responding firms said that alliances were “necessary.” MSOs and non-MSOs held differing views on just how necessary, however: While more than 40% of MSOs said that they were needed “immediately,” less than 20% of non-MSOs agreed (Figure 22).

Companies that believed alliances were necessary were asked about the kinds of partners they envisioned having. “Operators other than MSOs” was the most frequent response, followed by “MSOs.” The composition of the responses differed widely, however, depending on whether the respondent was an MSO or non-MSO. Among non-MSOs, “operators other than MSOs” drew the most responses, with “local government” drawing a fairly large number as well. Among MSOs, however, “operators other than MSOs” did not draw a single response (Figure 23).

Figure 22 Interest in Alliances (Single response; MSO/non-MSO)

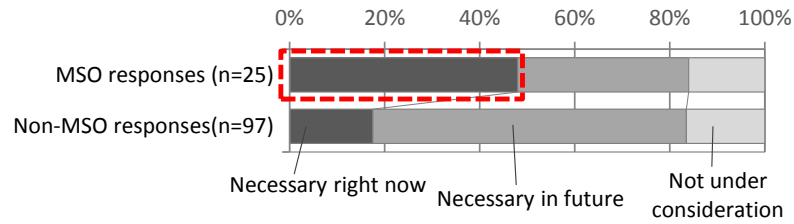

Source: Development Bank of Japan Inc.

Figure 23 Types of Partners Envisioned for an Alliance (Single response; MSO/non-MSO)

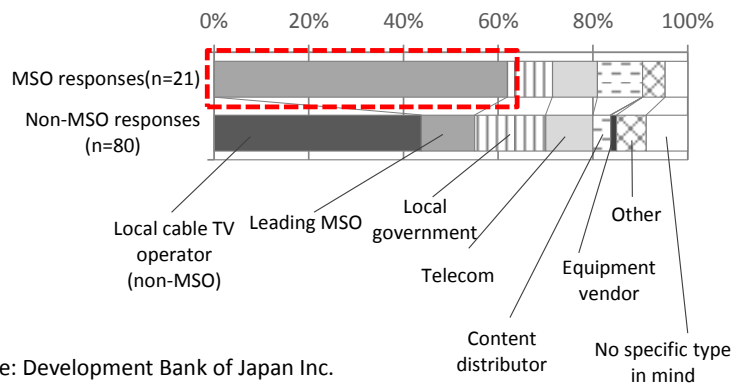

Source: Development Bank of Japan Inc.

Asked about the anticipated benefits of an alliance, some 60% of the respondents – the largest group – pointed to “lower costs through joint procurement of content and equipment.” Other benefits, mentioned by almost half of the respondents, included “new technology,” “business and customer relations skills,” and “enhanced distribution of local content.” MSOs were more likely than non-MSOs to cite “lower costs” and “business and customer relations skills,” and appeared to have particularly strong hopes about the latter (Figure 24).

Non-MSOs seemed to see greater potential benefit in “better distribution of local content” and “new technology.”

“Lower costs” was the potential benefit most frequently cited, both by companies envisioning an alliance with an MSO and those desiring one with a local cable company that was not an MSO (Figure 25).

The two groups differed, however, in their second most frequent response. For those envisioning an MSO as their partner, this was “business and customer relations skills,” while for those seeing their partner as a local cable operator it was “better distribution of local content.”

Finally, the companies were asked about the problems they would have to address in order to achieve an alliance. More than 70% pointed to “differences in management policy.” Companies envisioning a tie-up with an MSO were more likely to cite “additional costs” and “concern over whether the firm can stay relevant to the region” than those anticipating a local cable company as a partner. The second most common answer among the latter group, however, was “shareholders’ intentions” (Figure 26).

Figure 24 Desired Effects of an Alliance
(Multiple responses; MSO/non-MSO)

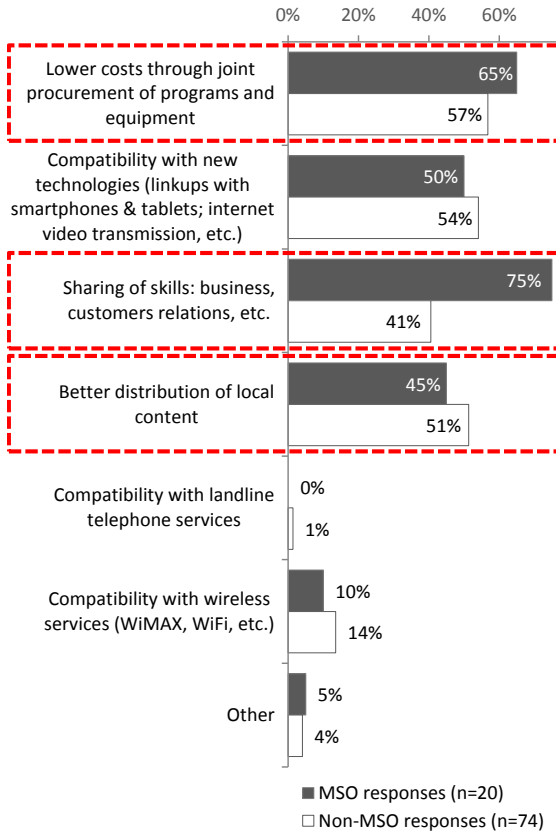

Figure 25 Desired Effects of an Alliance
(Multiple responses; partner is MSO/non-MSO)

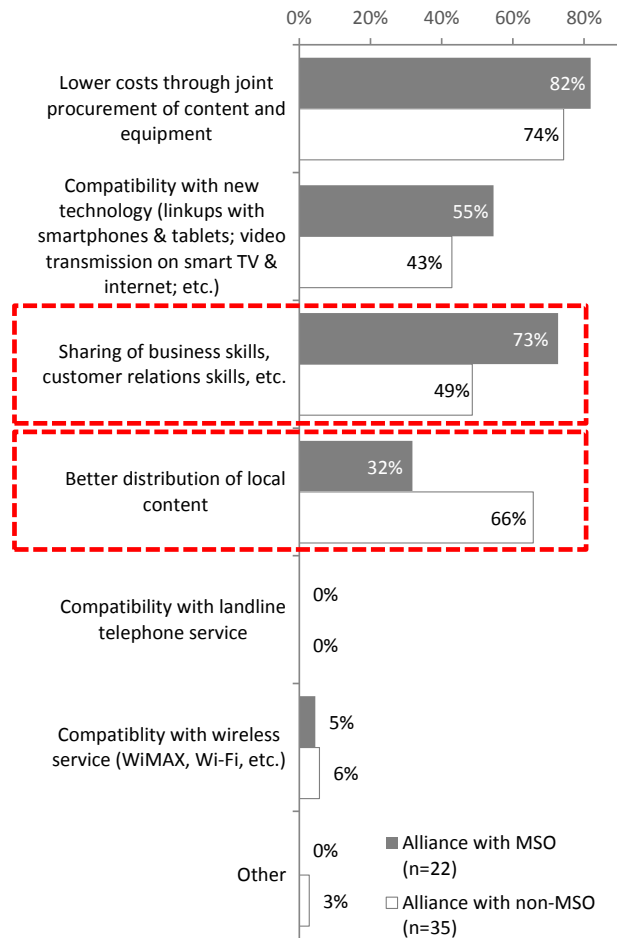
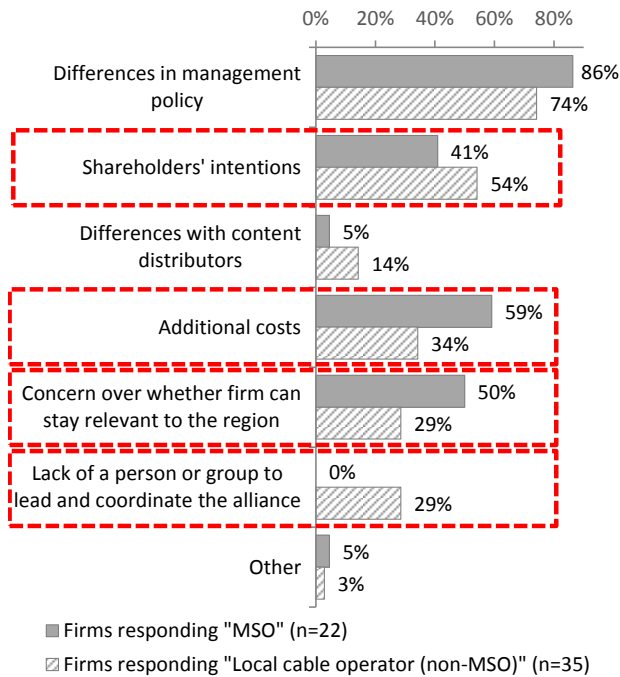

Figure 26 Obstacles in the Way of Alliances
(Multiple responses)



Source for Figs.24 through 26:
Development Bank of Japan Inc.

③ Alliance strategies

In expectation of further competition with telecoms and a shrinking market, cable television operators are weighing their options. The survey suggested that they were leaning towards two broad strategies: “greater ability to compete on cost,” and “differentiation through services tailored to the locality” (Figure 27). Alliances play a key role in each. On the vertical axis of the scale, we see that specific steps such as the joint use of facilities, joint purchasing of terminals and content, and integration of functions are already producing results for a number of companies.

On the horizontal axis, “differentiation through services tailored to the locality,” through tie-ups with a variety of local organizations, is shown to resolve local issues and enrich the lives of local residents.

Figure 27 Effects of Alliances on Competition Strategy

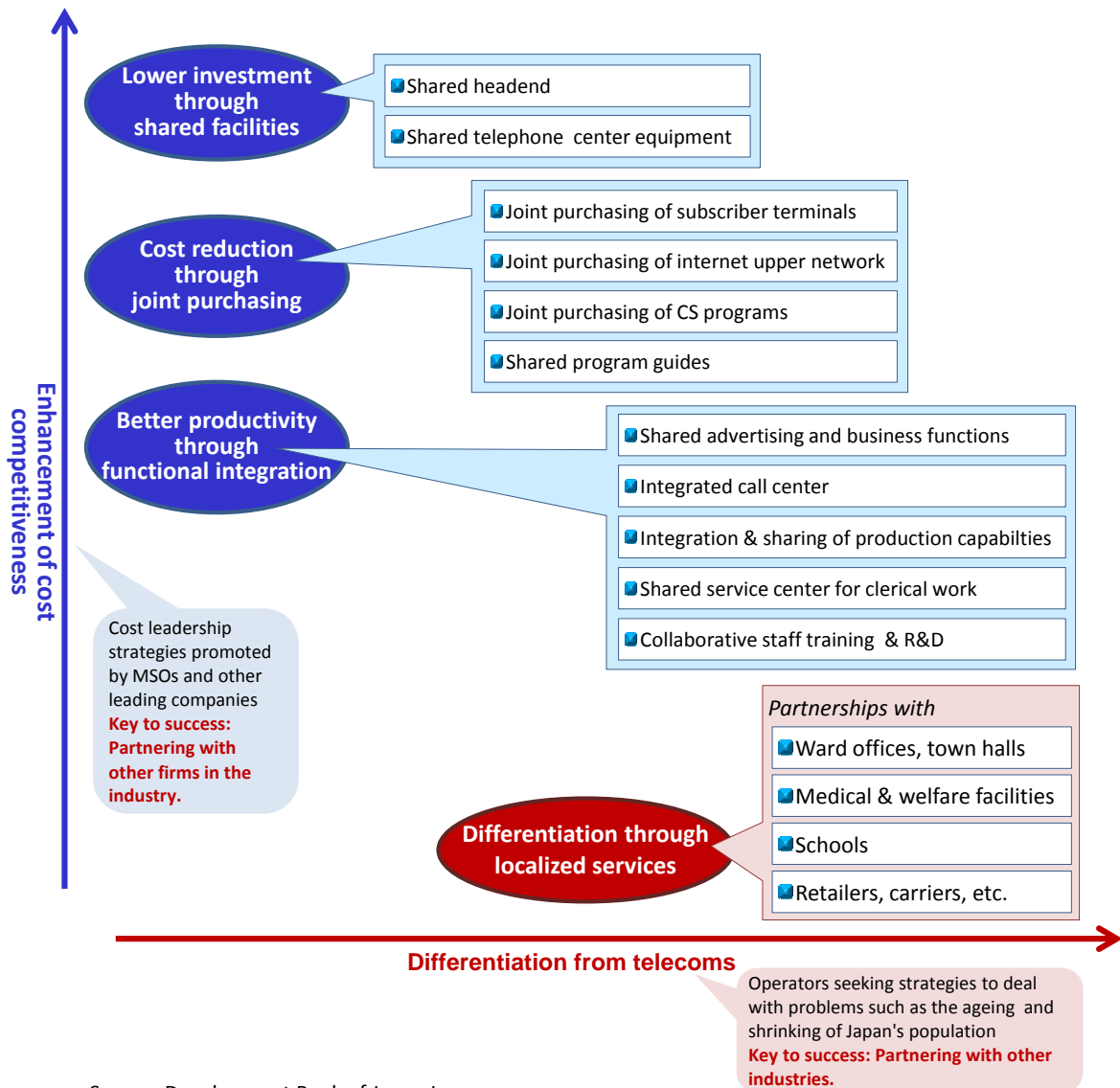

Source: Development Bank of Japan Inc.

The FY 2012 Report revealed signs of change in the business environment. Cable operators must take changing trends into account as they perform the urgent task of formulate their mid-to-long-term outlooks. As the questions on attitudes toward alliances made clear, momentum for alliances may be increasing, but companies' views on such tie-ups – and what they expect to gain from them – tend to differ. Japan's cable television operators must focus on creating alliance strategies that spell out which forms of cooperation will best suit their corporate needs.

Figure 28 Putting Alliance Strategies into Effect

<p>Partners:</p> <p>MSOs, independent operators, telecoms, local governments ...</p>
<p>Scope of alliance:</p> <p>Sharing of facilities, joint purchasing of programs, compatibility with new technologies ...</p>
<p>Expected results and advantages:</p> <p>Specific economic benefits</p> <p>Reduction in investment, services benefiting the general public ...</p> <p>Reduction in costs (approx. --- yen)</p>
<p>Obstacles and disadvantages:</p> <p>Capital problems, possible loss of independence ...</p>
<p>The right alliance for your firm?</p> <p>Area, scale ...</p>

Source: Development Bank of Japan Inc.

Hiroyuki Sawada,
 Corporate Finance Department, Division 2
 Makoto Shimizu,
 Economic & Industrial Research Department
 Development Bank of Japan Inc.

All inquiries should be directed to the Economic & Industrial Research Department,
Development Bank of Japan Inc.

the Economic & Industrial Research Department,
Development Bank of Japan Inc.

Phone: 03-3244-1840
E-mail: report@dbj.jp